



INDUSTRIAL BATTERY - VRLA-AGM BATTERY - MEDIUM AND LARGE SERIES

MODEL: EG65-12



Plane Chart:

Unit:(mm) Terminal type:(T3)

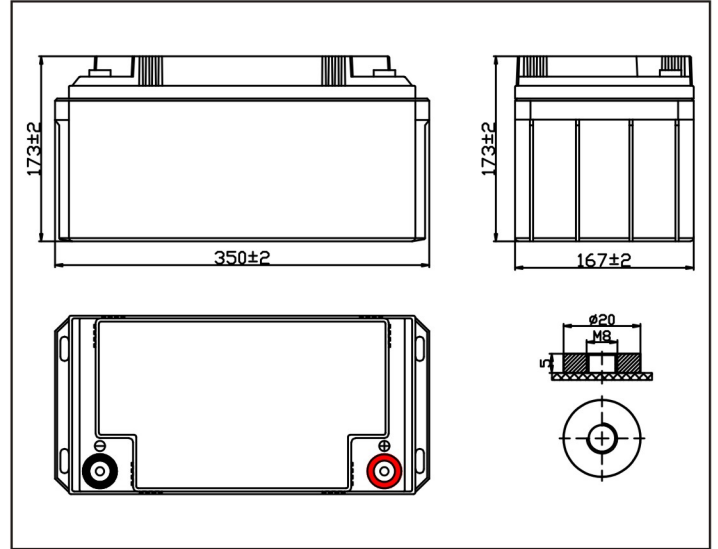

Parameter Chart:

Volts		12V	
Capacity(25°C)	10 hours rate (6.5A)	65Ah	
Discharge Current Testing (25°C)	1 hours rate (35.7A)	38Ah	
	3 hours rate (16.2A)	51Ah	
Internal Resistance	Full Charged Battery 25°C	6.5mΩ	
Design Life(25°C)	12 years		
Capacity Affected By Temperature	40°C	104%	
	25°C	100%	
	0°C	83%	
	-15°C	65%	
Residual Capacity (25°C)	Capacity After 3 Months Storage	91%	
	Capacity After 6 Months Storage	82%	
	Capacity After 12 Months Storage	65%	
Charge (Constant Voltage)	Cycle (25°C)	Initial Charging Current Less Than 19.5A Voltage 14.5~14.9V	
	Float (25°C)	Charge Voltage 13.6~13.8V	
Weight (Approx)		20.6Kg	

Residual Capacity

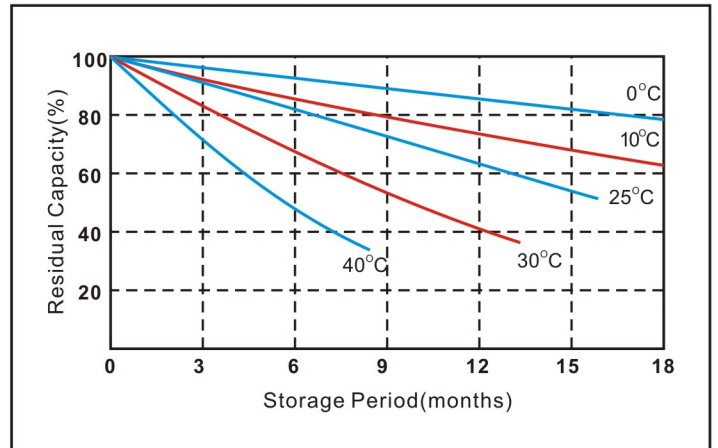

Discharge Current 25°C

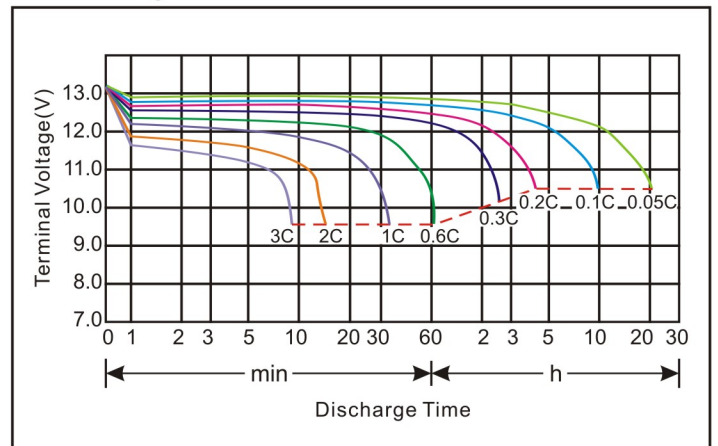

★ The above are average and data obtained from the first 3 charge/discharge cycles. These are not minimum values.



MODEL: EG65-12

Constant voltage charging characteristics

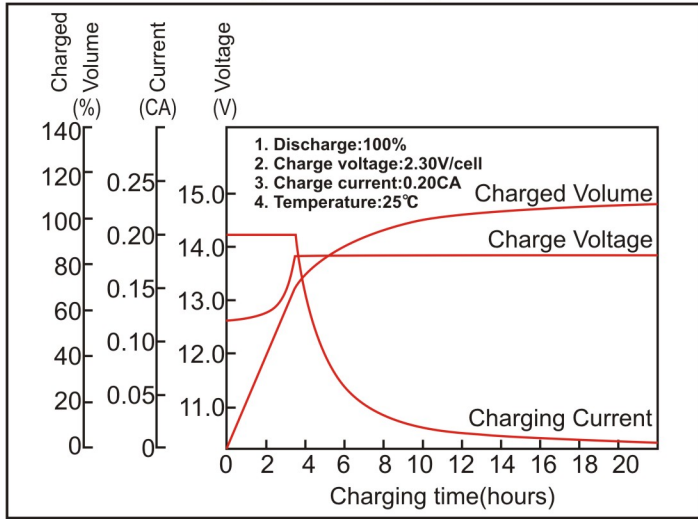

Float Life

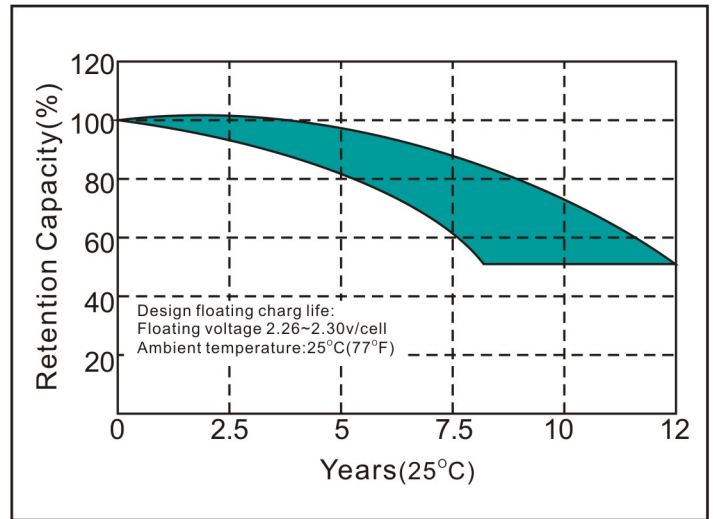

Constant Current Discharge Characteristics(A,25°C)

F.V/Time	5min	10min	15min	30min	60min	2h	3h	5h	8h	10h	20h
9.60V	205.4	143.3	110.2	67.1	41.1	23.7	16.7	11.7	7.9	6.7	3.5
10.2V	195.4	136.3	106.2	64.4	39.5	23.4	16.5	11.5	7.9	6.6	3.5
10.5V	190.4	132.3	103.2	63.1	38.6	23.2	16.3	11.4	7.8	6.5	3.4
10.8V	183.4	128.3	100.2	61.2	37.5	22.9	16.2	11.3	7.7	6.5	3.4

Constant Power Discharge Characteristic(Watt,25°C)

F.V/Time	5min	10min	15min	30min	60min	2h	3h	5h	8h	10h	20h
9.60V	2157.3	1547.1	1210.4	753.5	467.9	274.5	196.4	138.3	94.1	79.6	41.5
10.2V	2049.1	1469.9	1161.3	723.4	449.9	270.5	194.4	136.3	93.3	79.0	41.5
10.5V	1999.0	1427.9	1132.3	707.4	438.9	268.5	192.4	135.3	92.8	78.1	41.1
10.8V	1925.8	1381.8	1104.2	687.4	426.9	265.5	191.4	134.3	91.9	77.8	40.9

Capacity Factors With Different Temperature

Battery Type		-20°C	-10°C	0°C	5°C	10°C	20°C	25°C	30°C	40°C	45°C
Battery	12V	50%	70%	83%	85%	90%	98%	100%	102%	104%	105%

★The above are average and data obtained from the first 3 charge/discharge cycles. These are not minimum values.